

DENON

Hi-Fi Pre-Main Amplifier

SERVICE MANUAL MODEL PMA-717

SOLID STATE
PRE MAIN AMPLIFIER



For Service Manuals
MAURITRON SERVICES
8 Cherry Tree Road, Chinnor
Oxfordshire, OX9 4QY.
Tel (01844) 351694
Fax (01844) 352554
email:- sales@mauritron.co.uk

CONTENTS

SPECIFICATIONS	2
BLOCK DIAGRAM	2
DESIGNATION AND FUNCTIONS OF FRONT PANEL CONTROLS	3
CONNECTIONS	3
METHOD OF ADJUSTMENTS	4
REMOVAL OF EACH SECTION	5
PRINTED WIRING BOARD PATTERNS AND PARTS LIST	
ETC0717 POWER & CONTROL UNIT	6
CONNECTION DIAGRAM.....	8
WIRING DIAGRAM.....	11
SEMICONDUCTORS	11
EXPLODED VIEW OF CHASSIS AND CABINET & P/LIST	12

NIPPON COLUMBIA CO., LTD.

APR. 1984

SPECIFICATIONS

POWER AMPLIFIER SECTION

Rated Output Power: Both channel drive (TUNER → SP OUT)
35 Watts minimum rms per channel into 8 ohms with less than 0.05% total harmonic distortion from 20 Hz to 20 kHz.
1 kHz (8 ohm Load) 40 W + 40 W (IEC Subject to change by temperature test)

Total Harmonic Distortion: 0.03% (20 Hz – 20 kHz at –3 dB rated output 8 ohm Load) (IHF)
0.05% (20 Hz – 20 kHz at rated output 8 ohm Load) (U.S.A.)

Intermodulation Distortion: Below 7 kHz / 60 Hz: 1/4 0.01% (at amplitude output equivalent to rated output)

Output Band Width: 10 Hz – 40 kHz (IHF THD 0.1%)

Transmission Characteristics: 5 Hz – 150 kHz $\begin{matrix} +0 \\ -3 \end{matrix}$ dB (at 1 W output)

Input Sensitivity: 150 mV

Input Impedance: 30 k ohm

Output Impedance: 0.16 ohm (1 kHz)

Output Terminals: Speaker: A and B Load 8 – 16 ohm
Headphone/Stereo headphone (140 mW/8 ohm)

Input Sensitivity/

Input Impedance: PHONO MM: 2.5 mV 47 k ohm
MC: 0.2 mV 100 ohm
TUNER 150 mV 30 k ohm
DAD/AUX, TAPE 150 mV 30 k ohm

RIAA Deviation: PHONO MC: within ±0.5 dB (20 Hz – 100 kHz)

GENERAL CHARACTERISTICS

SN Ratio (IHFA Network): PHONO
MM: 86 dB (input terminals short-circuited for 2.5 mV input)
MC: 70 dB (input terminals short-circuited for 250 μV input)
TUNER, DAD/AUX, TAPE: 96 dB (input terminals short-circuited)

Tone Control Adjustable

Range: BASS 100 Hz ± 10 dB
TREBLE 10 kHz ± 10 dB

Loudness Characteristics:

Low frequency 100 Hz + 8 dB
High frequency 10 kHz + 6 dB
SWITCHED x 2, 100 W (Total)
UNSWITCHED x 1, 250 W

AC OUTLET:

(For U.S.A., Canada and Asia)

POWER SOURCE:

Germany and France AC 220 V, 50 Hz; U.K. and Australia AC 240 V, 50 Hz; U.S.A. and Canada AC 120 V, 60 Hz; Asia AC 110/120/220/240 V, 50/60 Hz (Multiple)

POWER CONSUMPTION:

70 W (Multiple); 145 VA (CSA), 90 W (IEC), 70 W (USA)
230 W (Maximum output)

DIMENSIONS:

434 mm (W) x 97.5 mm (H) x 286 mm (D) (including rubber feet, control knobs, and terminals)

WEIGHT:

6.5 kg

Design and specifications are subject to change without prior notice.

NOTE: The following codes correspond to the appropriate models.
E2 for Europe, EK for U.K., E3 for U.S.A., and E1 for Asia.
This Service Manual is prepared based on E2 and gold version.

BLOCK DIAGRAM

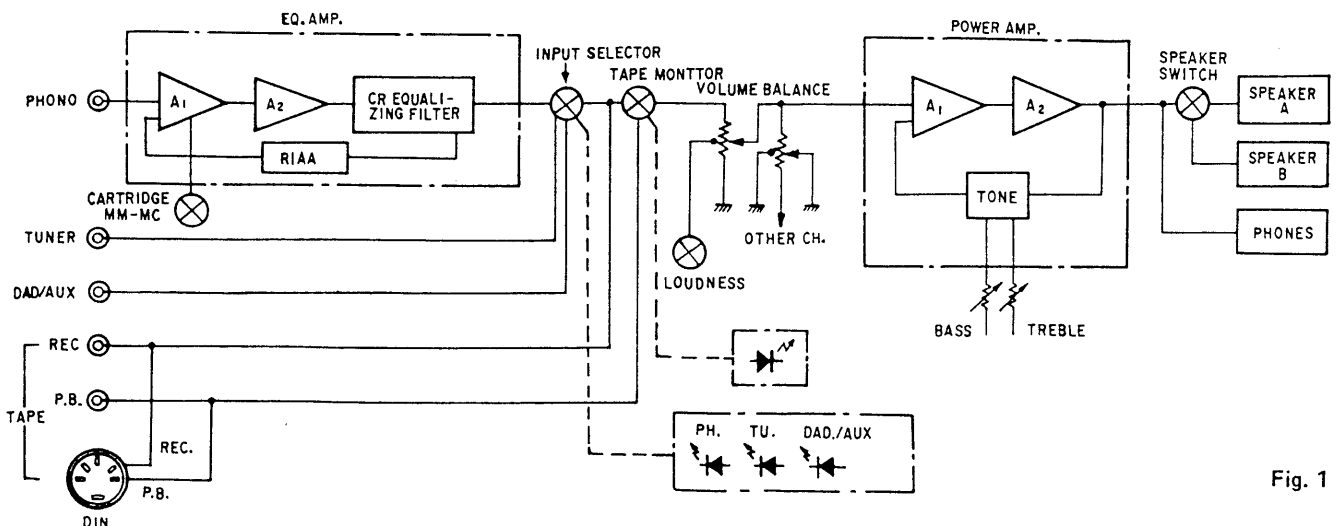

Fig. 1

DESIGNATION AND FUNCTIONS OF FRONT PANEL CONTROLS

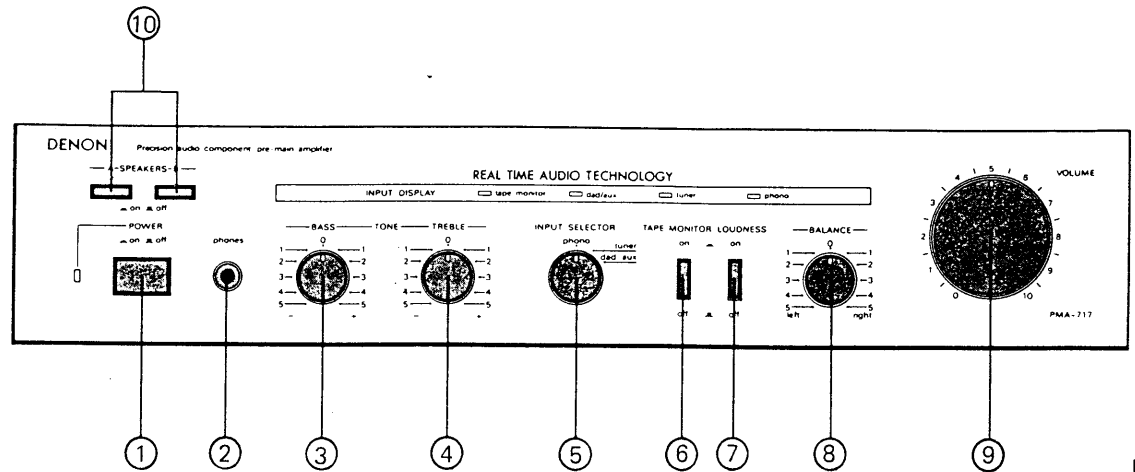

Fig. 2

- | | |
|--|--|
| ① POWER (Power On-Off Switch) | ⑥ TAPE MONITOR (Tape Monitor Switch) |
| ② Phones (Headphone Jack) | ⑦ LOUDNESS (Loudness Switch) |
| ③ BASS (Bass Control) | ⑧ BALANCE (Balance Control) |
| ④ TREBLE (Treble Control) | ⑨ VOLUME (Volume Control) |
| ⑤ INPUT SELECTOR (Input Selector Switch) | ⑩ SPEAKERS (Speaker Changeover Switch) |
- Phono, ● tuner, ● dad/aux

CONNECTIONS

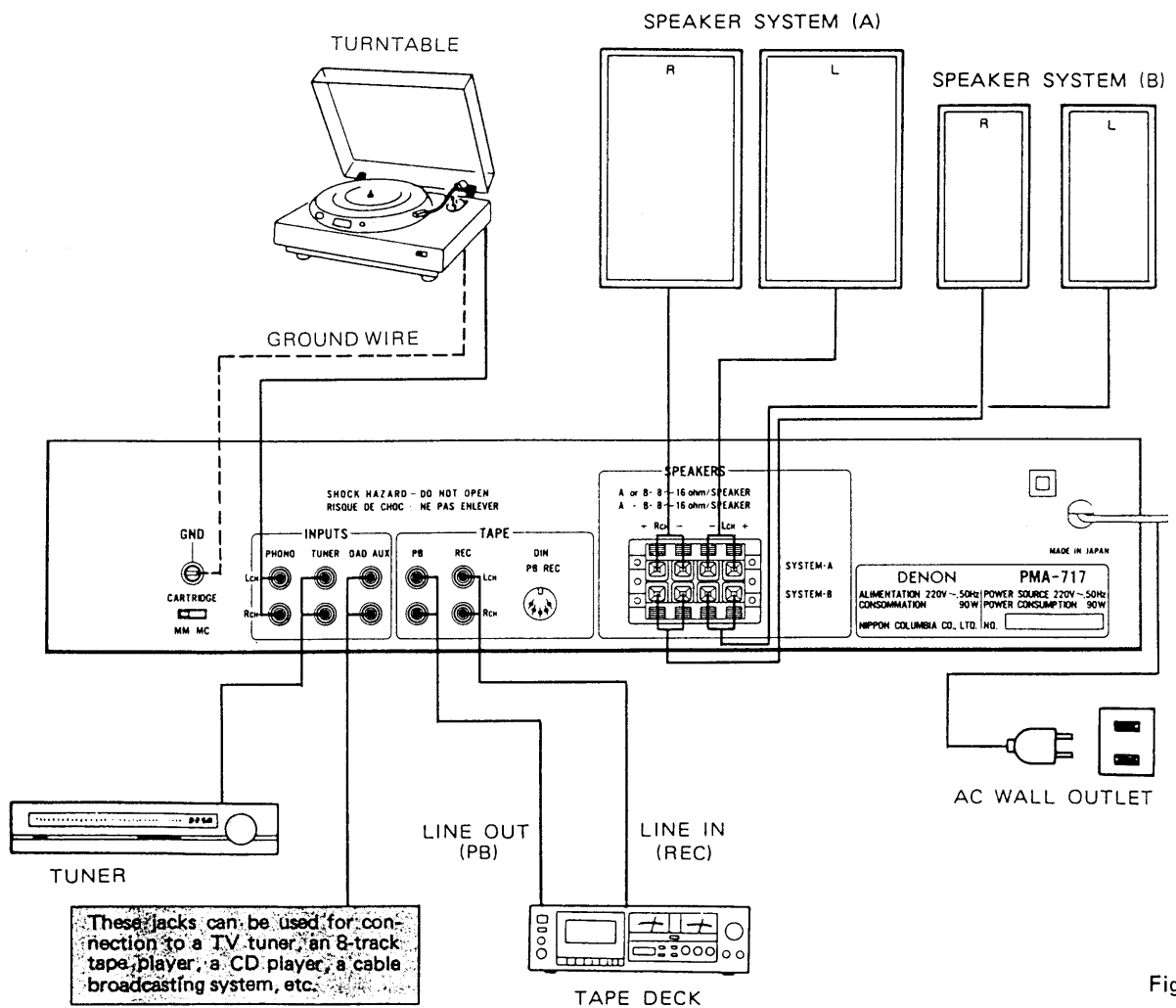

Fig. 3

METHOD OF ADJUSTMENTS

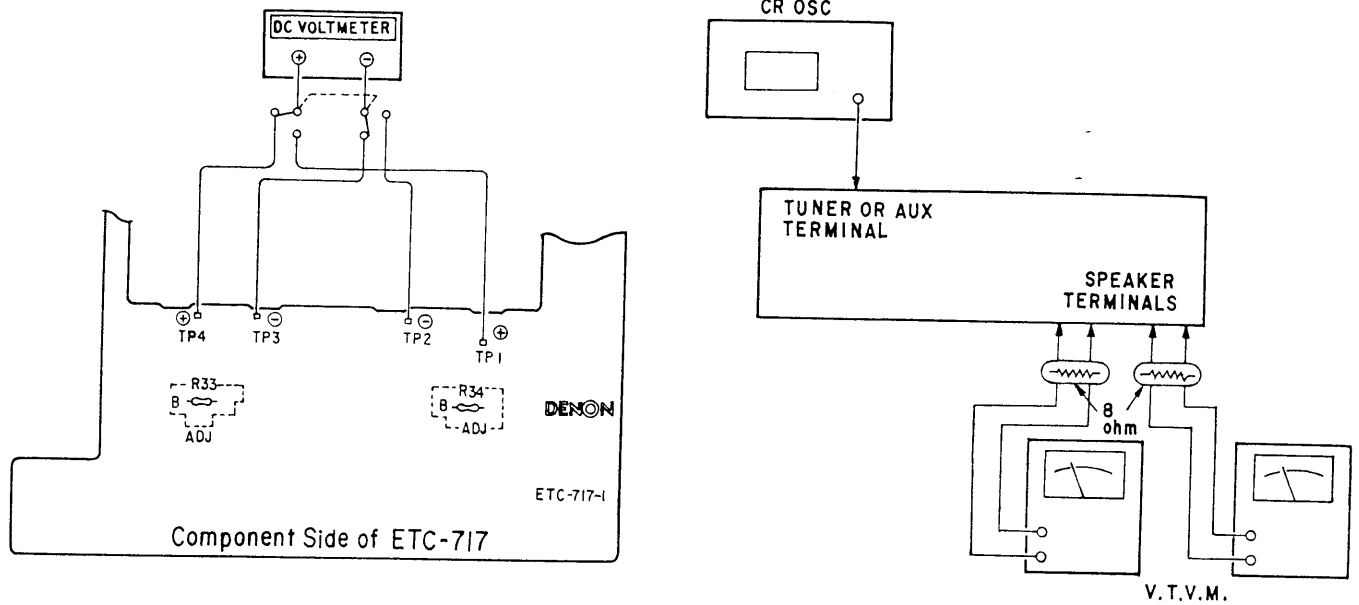

Fig. 4

IDLE CURRENT ADJUSTMENT (Fig. 4)

1. Keep the unit away from direct wind blown by an air-conditioner and an electric fan, and keep the unit under normal conditions. Adjust the range of ambient temperature to 15 – 30°C.
2. Set the following switches as follows:
 - POWER (power switch) to off
 - VOLUME (VOLUME CONTROL) to 0 (C)
 - SPEAKERS (speaker terminal) to no load (speakers disconnected)
3. Remove the top cover and connect a DC digital voltmeter to the test points of ETC0717 (power and control units) (between the positive terminal TP4⊕ and the negative terminal TP3⊖, and between the positive TP1⊕ and the negative terminal TP2⊖).
4. Connect the power source cord to an AC outlet and turn on the power switch; read the measured value after 3 minutes or when the measured value is within a tolerance 6 mV ~ 90 mV (DC), adjust the idling current manually as follows.
 - (1) Connect a 4.7 ohm resistor to resistors R33 and 34 which are surrounded by the broken line on the printed circuit board.
 - (2) When the voltmeter reads 6 mV (DC) or less under the condition of item (1), disconnect the 4.7 ohm from resistors R33 and R34.

REMOVAL OF EACH SECTION

1. Removal of Top Cover (Fig. 5)

- 1) Remove four screws at both sides of the Top Cover.
- 2) Gently widen the lower parts of the Top Cover to remove it upward.

NOTE:

Be careful to minimize the clearance (Shown by the asterisk mark) between the Top Cover and the Front Panel when mounting.

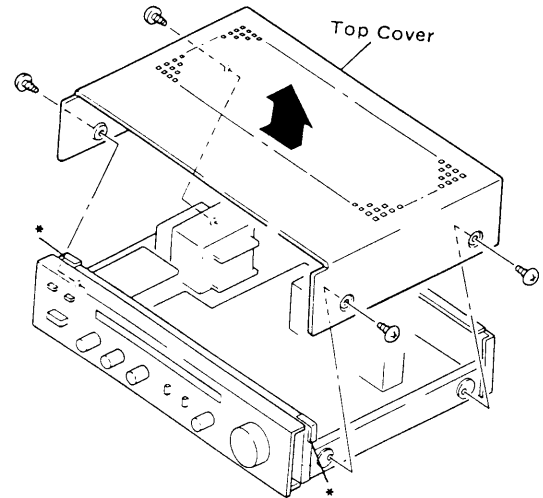

Fig. 5

2. Removal of Rear Panel (Fig. 6)

- 1) Remove four screws (A).
- 2) Remove two ribets (B).
- 3) Remove ten screws (C) securing the Bottom Cover.

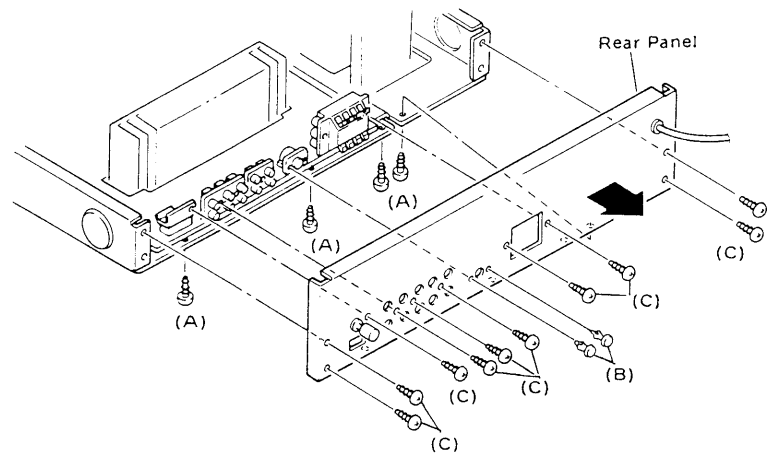

Fig. 6

3. Removal of Front Panel (Fig. 7)

Remove five screws securing the Front Panel.

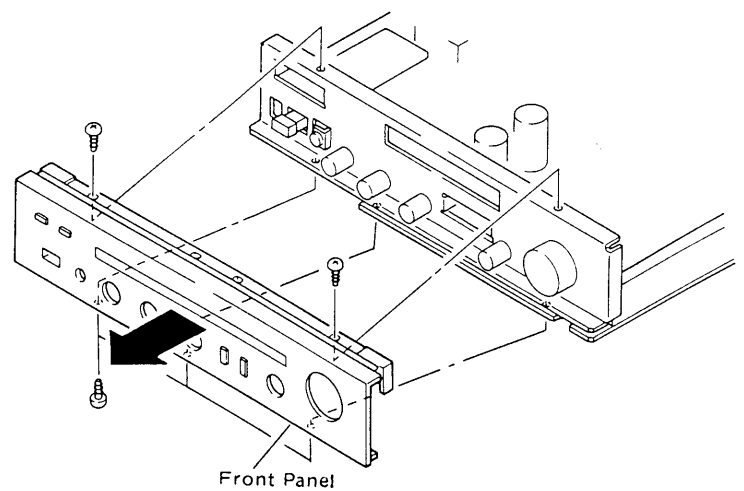

Fig. 7

PRINTED WIRING BOARD PATTERNS AND PARTS LIST

ETC0717 POWER & CONTROL UNIT PARTS LIST

Ref. No.	Part No.	Part Name & Descriptions
SEMICONDUCTORS		
IC001	2630250008	NJM4558D (JRC) IC
IC005, 006	2630206007	μ PC1225H (NEC) IC
TR001, 002	2730198015	2SC1815(BL) TRANSISTOR
TR017, 018	2730237031	2SC2577(O/Y) TRANSISTOR
TR019, 020	2710136039	2SA1102(O/Y) TRANSISTOR
TR021	2730163040	2SC1735(D)/E TRANSISTOR
TR022	2710072025	2SA850(D)/(E) TRANSISTOR
TR023	2740088005	2SD1406(O)/(Y) TRANSISTOR
TR024	2710178039	2SA564A(R) TRANSISTOR
TR101, 102	2750045009	2SK389(BL)/(V) FET
D001, 002	2760049008	1S2076 DIODE
D005, 006	2760049008	1S2076 DIODE
D009, 010	2760049008	1S2076 DIODE
D013, 014	2760049008	1S2076 DIODE
D019, 020	2760049008	1S2076 DIODE
D021	2760249002	HZ18-2 ZENER
D022	3939051004	SEL1110R (RED) LED
D023	2760232006	U08C DIODE
~026		
D031, 033, 035	3939052003	SEL1310G (GREEN) LED
D037	3939154008	PR5552K-1 (RED) LED
RESISTORS (not included Carbon Film \pm5%, 1/4W Type)		
R041	2442031004	33 ohm \pm 5% 2W METAL OXIDE (FR)
R055, 056	2440049027	4.7k ohm \pm 5% 1W METAL OXIDE (NB)
R065, 066	2440049027	4.7k ohm \pm 5% 1W METAL OXIDE (NB)
R073, 074	2432033012	0.33/0.33 ohm \pm 10% 2W WIRE WOUND
R077, 078	2410137008	10 ohm \pm 5% 1/2W CARBON
R097, 098	2440030023	120 ohm \pm 5% 1W METAL OXIDE (NB)
R101	2412313037	220 ohm \pm 2% 1/4W CARBON (FR)
R104	2412313040	390 ohm \pm 2% 1/4W CARBON (FR)
R109	2410189001	1.5k ohm \pm 5% 1/2W CARBON
R115	2410181009	680 ohm \pm 5% 1/2W CARBON
R151, 152	2412313082	4.7 ohm \pm 5% 1/4W CARBON (FR)
R201, 202	2440047029	3.3k ohm \pm 5% 1W METAL OXIDE (NB)
VR001	2110251006	VARIABLE RESISTOR 100k ohm FOR MAIN
VR002	2110245106	VARIABLE RESISTOR 250k ohm FOR BALANCE
VR005	2110246118	VARIABLE RESISTOR 100k ohm FOR BASS
VR006	2110246118	VARIABLE RESISTOR 100k ohm FOR TREBLE

Ref. No.	Part No.	Part Name & Descriptions
CAPACITORS (not included Ceramic \pm5%, \pm10%, 50V Type)		
C005, 006	2544161050	100 μ F \pm 20% 6.3V ELECTROLYTIC
C007, 008	2551121067	0.022 μ F \pm 5% 50V PLASTIC FILM
C009, 010	2551121009	0.0068 μ F \pm 5% 50V PLASTIC FILM
C011, 012	2544146004	1 μ F 50V ELECTROLYTIC
C015, 016	2551122008	0.047 μ F \pm 5% 50V PLASTIC FILM
C017, 018	2544146004	1 μ F 50V ELECTROLYTIC
C021	2544146004	1 μ F 50V ELECTROLYTIC
~024		
C025, 026	2544142008	22 μ F 35V ELECTROLYTIC
C035, 036	2533603008	10pF \pm 0.5pF 50V CERAMIC
C039	2544145005	0.47 μ F 50V ELECTROLYTIC
C042	2544060025	1 μ F 100V ELECTROLYTIC
C045, 046	2531027000	0.1 μ F +80,-20% 50V CERAMIC
C047, 048	2543013028	33 μ F 10V ELECTROLYTIC(B.P)
C049, 050	2551121083	0.033 μ F \pm 5% 50V PLASTIC FILM
C051, 052	2551085006	0.12 μ F \pm 10% 50V PLASTIC FILM
C053, 054	2551120013	0.0012 μ F \pm 5% 50V PLASTIC FILM
C055, 056	2551120097	0.0056 μ F \pm 5% 50V PLASTIC FILM
C059, 060	2544146004	1 μ F 50V ELECTROLYTIC
C062, 063	2544146004	1 μ F 50V ELECTROLYTIC
C064	2544050006	100 μ F 50V ELECTROLYTIC
C066, 067	2546072008	5600 μ F \pm 20% 45V ELECTROLYTIC
C068	2531053003	0.01 μ F +100,-0% 500V CERAMIC
C071	2531024003	0.01 μ F +80,-20% 50V CERAMIC
~074		
C077, 078	2551120000	0.001 μ F \pm 5% 50V PLASTIC FILM
C079, 080	2531024003	0.01 μ F +80,-20% 50V CERAMIC
C093, 094	2531027000	0.1 μ F +80,-20% 50V CERAMIC
C097	2531024003	0.01 μ F +80,-20% 50V CERAMIC
C213	2531024003	0.01 μ F +80,-20% 50V CERAMIC
C301, 302	2551120084	0.0047 μ F \pm 5% 50V PLASTIC FILM
C303, 304	2533603008	10pF \pm 0.5pF 50V CERAMIC
C305	2531024003	0.01 μ F +80,-20% 50V CERAMIC
C307	2531024003	0.01 μ F +80,-20% 50V CERAMIC
C309, 310	2531053003	0.01 μ F +100,-0% 50V CERAMIC
C311, 312	2531007004	3300pF \pm 10% 50V CERAMIC
C313	2544139008	100 μ F 25V ELECTROLYTIC

ETC0717K POWER & CONTROL UNIT
P/LIST For E1
(Same as ETC0717 except the followings)

Ref. No.	Part No.	Part Name & Descriptions
SWITCH		
SW001	2124509003	SLIDE SW (4-4) REMOTE FOR INPUT SEL.
SW002, 003	2124494008	2P PUSH SWITCH FOR LOUD. MONI.
SW004	2124311107	SLIDE SWITCH FOR MM/MC
SW005	2124486003	2P PUSH SWITCH FOR S.P.
FUSE		
△ F001	2061015058	FUSE 1.6A (250V)
F002, 003	2061015074	FUSE 3.15A (250V)
OTHER PARTS		
	2221066106	P.W. BOARD
	2090008120	JUMPER WIRE P=10mm
	EP5667H1	TERMINAL PIN
	2090008162	JUMPER WIRE P=20mm 2
	2050152003	6P CONNECTOR BASE
	2050150005	4P CONNECTOR BASE FOR TAPE
	2050151004	8P PUSH TERMINAL FOR SP
	2048047007	HEAD PHONE JACK
	2048059008	DIN JACK (5P) FOR TAPE
△	2020022008	FUSE HOLDER 6
	1220109007	BLIND SHEET
	4410412200	LED HOLDER
	4170175007	POWER RADIATOR
	4121079000	RADIATOR BRACKET 2
	4730354019	TAPPING SCREW (2) 3x8 6
	4700012022	PAN SCREW WITH W. S.W 3x12 5
	4171071001	RADIATOR 2
	4730353010	TAPPING SCREW (2) 3x6 2
	2030230042	1P CONNECTOR
	2032141016	2P CONNECTOR CORD
	2032108033	2P CONNECTOR CORD
	2034189005	3P CONNECTOR CORD
	2050185038	3P WIRE HOLDER 14
	2050185070	7P WIRE HOLDER 2
	2050190036	3P NH CONNECTOR BASE
	2050190023	2P NH CONNECTOR BASE
	4150234007	INSULATING SHEET 4

Ref. No.	Part No.	Part Name & Descriptions
SEMICONDUCTOR		
IC001	2650030004	NJM4558D-D (JRC) (CHANGE)
RESISTORS		
R001, 002	2412044005	10 ohm ±5% 1/4W CARBON (CHANGE)
R041	2440080028	33 ohm ±5% 2W METAL OXIDE (NB) (CHANGE)
R043, 044	2412068007	100 ohm ±5% 1/4W CARBON (DELETE)
R129, 130	2412156003	470k ohm ±5% 1/4W CARBON (DELETE)
R151, 152	2412313082	4.7 ohm ±5% 1/4W CARBON (FR) (DELETE)
R307, 308	2412084007	470 ohm ±5% 1/4W CARBON (CHANGE)
CAPACITORS		
C071 ~074	2531024003	0.01μF +80,-20% 50V CERAMIC (DELETE)
C079, 080	2531024003	0.01μF +80,-20% 50V CERAMIC (DELETE)
C081, 082	2533609002	18pF ±5% 50V CERAMIC (DELETE)
C095, 096	2533645008	560pF ±5% 50V CERAMIC (DELETE)
C201, 202	2533613001	27pF ±5% 50V CERAMIC (DELETE)
C203, 204	2533635005	220pF ±5% 50V CERAMIC (DELETE)
C209, 210	2533635005	220pF ±5% 50V CERAMIC (CHANGE)
C215, 216	2533627000	100pF ±5% 50V CERAMIC (DELETE)
C303, 304	2533603008	10pF ±0.5pF 50V CERAMIC (DELETE)
C305	2531024003	0.01μF +80,-20% 50V CERAMIC (DELETE)
C307	2531024003	0.01μF +80,-20% 50V CERAMIC (DELETE)
C309, 310	2531053003	0.01μF +100,-0% 500V CERAMIC (DELETE)
C311, 312	2531007004	3300pF ±10% 50V CERAMIC (DELETE)
OTHER PARTS		
	2090008120	JUMPER WIRE P=10mm 124 (CHANGE)
	2033909008	AC OUTLET (ADD)
	EP-5667H1	TERMINAL 4 (ADD)
	EP-5870	FUSE HOLDER 2 (ADD)
	2061025080	FUSE 3.15A (TLC) (ADD)
	5130159143	FUSE LABEL (T.3.15A) (ADD)
	2048059008	DIN JACK (5P) (DELETE)
	2030230042	1P CONNECTOR (DELETE)

ETC0717L POWER & CONTROL UNIT
P/LIST For EK
(Same as ETC0717 except the followings)

Ref. No.	Part No.	Part Name & Descriptions
SEMICONDUCTOR		
IC001	2650030004	NJM4558D-D (JRC) (CHANGE)
RESISTORS		
R001, 002	2412044005	10 ohm $\pm 5\%$ 1/4W CARBON (CHANGE)
R041	2440080028	33 ohm $\pm 5\%$ 2W METAL OXIDE (NB) (CHANGE)
R151, 152	2412313082	4.7 ohm $\pm 5\%$ 1/4W CARBON (FR) (DELETE)
R307, 308	2412084007	470 ohm $\pm 5\%$ 1/4W CARBON (CHANGE)
CAPACITORS		
C071 ~074	2531024003	0.01 μ F +80,-20% 50V CERAMIC (DELETE)
C079 080	2531024003	0.01 μ F +80,-20% 50V CERAMIC (DELETE)
C095, 096	2533645008	560pF $\pm 5\%$ 50V CERAMIC (DELETE)
C201, 202	2533613001	27pF $\pm 5\%$ 50V CERAMIC (DELETE)
C203, 204	2533635005	220pF $\pm 5\%$ 50V CERAMIC (DELETE)
C209, 210	2533635005	220pF $\pm 5\%$ 50V CERAMIC (CHANGE)
C215, 216	2533627000	100pF $\pm 5\%$ 50V CERAMIC (DELETE)
C303, 304	2533603008	10pF ± 0.5 pF 50V CERAMIC (DELETE)
C305, 307	2531024003	0.01 μ F +80,-20% 50V CERAMIC (DELETE)
C309, 310	2531053003	0.01 μ F +100,-0% 500V CERAMIC (DELETE)
C311, 312	2531007004	3300pF $\pm 10\%$ 50V CERAMIC (DELETE)
OTHER PARTS		
	2090008120	JUMPER WIRE P=10mm 124 (CHANGE)
	2030230042	1P CONNECTOR (DELETE)

ETC0717M POWER & CONTROL UNIT
P/LIST For E3
(Same as ETC0717 except the followings)

Ref. No.	Part No.	Part Name & Descriptions
SEMICONDUCTOR		
IC001	2650030004	NJM4558D-D (JRC) (CHANGE)
RESISTORS		
R001, 002	2412044005	10 ohm $\pm 5\%$ 1/4W CARBON (CHANGE)
R041	2440080028	33 ohm $\pm 5\%$ 2W METAL OXIDE (NB) (CHANGE)
R043, 044	2412068007	100 ohm $\pm 5\%$ 1/4W CARBON (DELETE)
R129, 130	2412156003	470k ohm $\pm 5\%$ 1/4W CARBON (DELETE)
R151, 152	2412313082	4.7 ohm $\pm 5\%$ 1/4W CARBON (FR) (DELETE)
R307, 308	2412084007	470 ohm $\pm 5\%$ 1/4W CARBON (CHANGE)
CAPACITORS		
C071 ~074	2531024003	0.01 μ F +80,-20% 50V CERAMIC (DELETE)
C079, 080	2531024003	0.01 μ F +80,-20% 50V CERAMIC (DELETE)
C081 082	2533609002	18pF $\pm 5\%$ 50V CERAMIC (DELETE)
C095, 096	2533645008	560pF $\pm 5\%$ 50V CERAMIC (DELETE)
C201, 202	2533613001	27pF $\pm 5\%$ 50V CERAMIC (DELETE)
C203, 204	2533635005	220pF $\pm 5\%$ 50V CERAMIC (DELETE)
C209, 210	2533635005	220pF $\pm 5\%$ 50V CERAMIC (CHANGE)
C215, 216	2533627000	100pF $\pm 5\%$ 50V CERAMIC (DELETE)
C303, 304	2533603008	10pF ± 0.5 pF 50V CERAMIC (DELETE)
C305	2531024003	0.01 μ F +80,-20% 50V CERAMIC (DELETE)
C307	2531024003	0.01 μ F +80,-20% 50V CERAMIC (DELETE)
C309, 310	2531053003	0.01 μ F +100,-0% 500V CERAMIC (DELETE)
C311, 312	2531007004	3300pF $\pm 10\%$ 50V CERAMIC (DELETE)
OTHER PARTS		
	2090008120	JUMPER WIRE P=10mm (CHANGE)
	2033909008	AC OUTLET (ADD)
	EP-5667H1	TERMINAL 2 (ADD)
	2061039089	FUSE 3.15A 3 (ADD)
F001 ~003	2061015058	FUSE 1.6A (DELETE)
	5130854008	FUSE LABEL (T3.15A) (ADD)
	5130607093	FUSE LABEL (ADD)
	2048059008	DIN JACK (5P) (DELETE)
	2030230042	1P CONNECTOR (DELETE)

ETC0717N POWER & CONTROL UNIT
P/LIST For EA
(Same as ETC0717 except the followings)

ETC0717 POWER & CONTROL UNIT

Ref. No.	Part No.	Part Name & Descriptions
SEMICONDUCTOR		
IC001	2650030004	NJM4558D-D (JRC) (CHANGE)
RESISTORS		
R001, 002	2412044005	10 ohm ±5% 1/4W CARBON (CHANGE)
R041	2440080028	33 ohm ±5% 2W METAL OXIDE (NB) (CHANGE)
R151, 152	2412313082	4.7 ohm ±5% 1/4W CARBON (FR) (DELETE)
R307, 308	2412084007	470 ohm ±5% 1/4W CARBON (CHANGE)
CAPACITORS		
C071 ~074	2531024003	0.01 μF +80, -20% 50V CERAMIC (DELETE)
C079, 080	2531024003	0.01 μF +80, -20% 50V CERAMIC (DELETE)
C095, 096	2533645008	560pF ±5% 50V CERAMIC (DELETE)
C201, 202	2533613001	27pF ±5% 50V CERAMIC (DELETE)
C203, 204	2533635005	220pF ±5% 50V CERAMIC (DELETE)
C209, 210	2533635005	220pF ±5% 50V CERAMIC (CHANGE)
C215, 216	2533627000	100pF ±5% 50V CERAMIC (DELETE)
C303, 304	2533603008	10pF ±0.5pF 50V CERAMIC (DELETE)
C305, 307	2531024003	0.01 μF +80, -20% 50V CERAMIC (DELETE)
C309, 310	2531053003	0.01 μF +100, -0% 500V CERAMIC (DELETE)
C311, 312	2531007004	3300pF ±10% 50V CERAMIC (DELETE)
OTHER PARTS		
	2090008120	JUMPER WIRE P=10mm 124 (CHANGE)
	2030230042	1P CONNECTOR (DELETE)

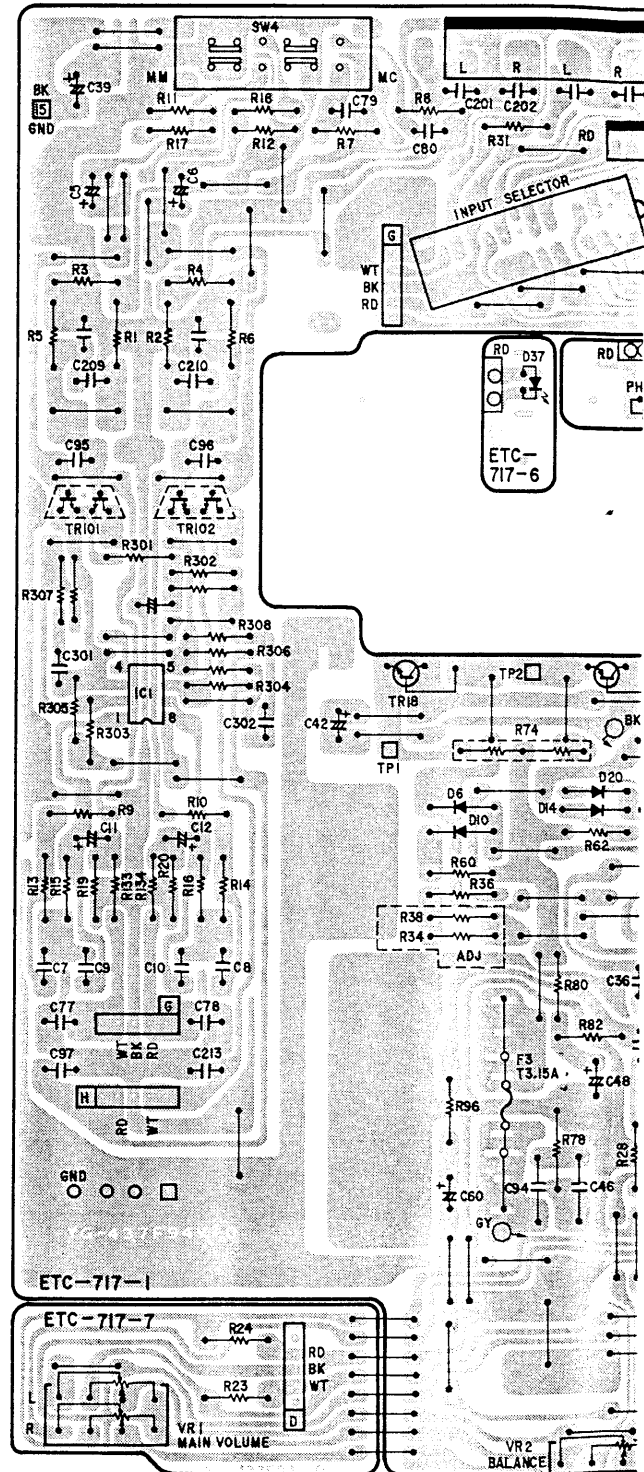

ETC0717 POWER & CONTROL UNIT

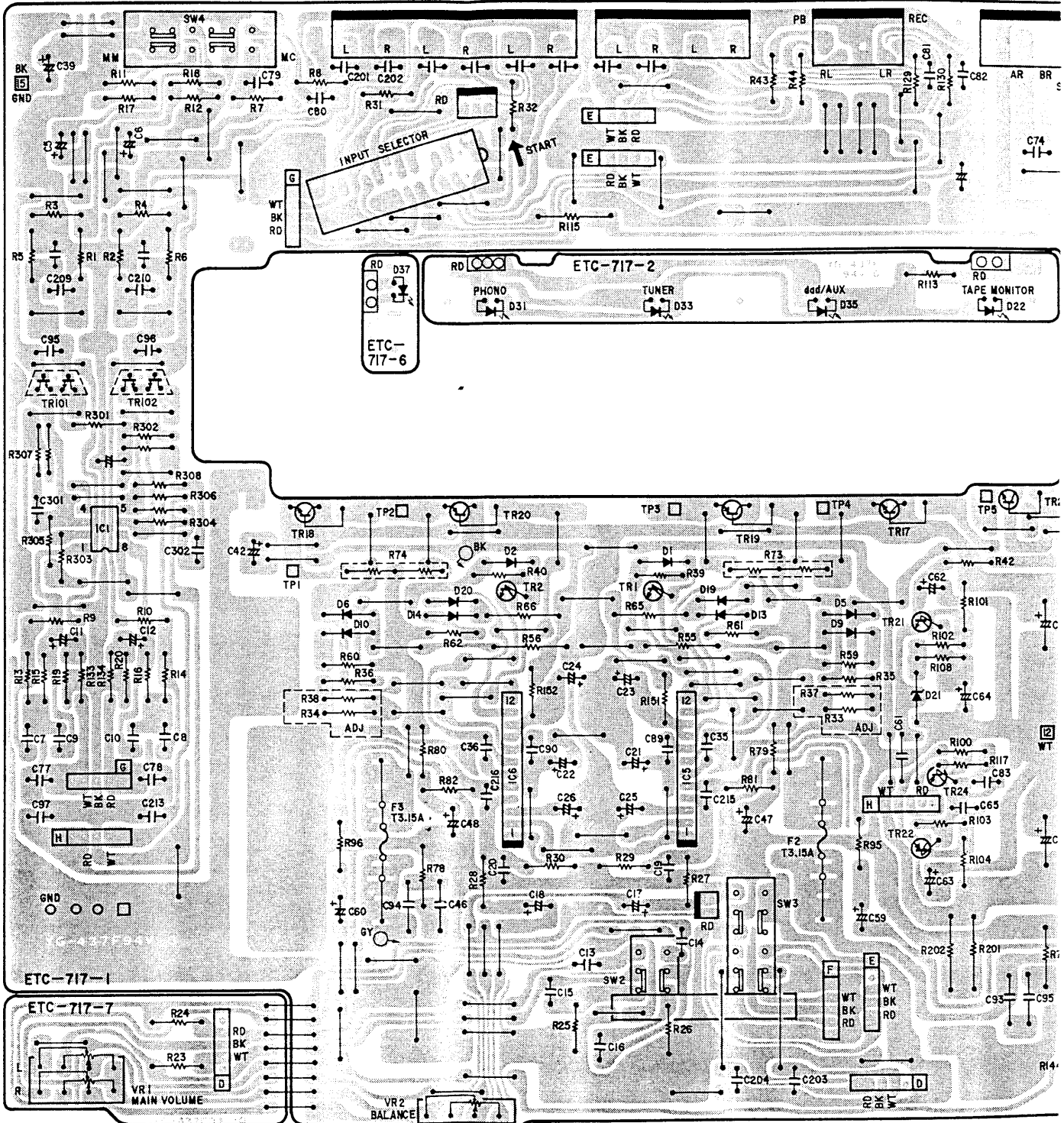

For Service Manuals
MAURITRON SERVICES
 8 Cherry Tree Road, Chinnor
 Oxfordshire, OX9 4QY.
 Tel (01844) 351694
 Fax (01844) 352554
 email:- sales@mauritron.co.uk

CONNECTION DIAGRAM
(This figure is the specifications of E2.)

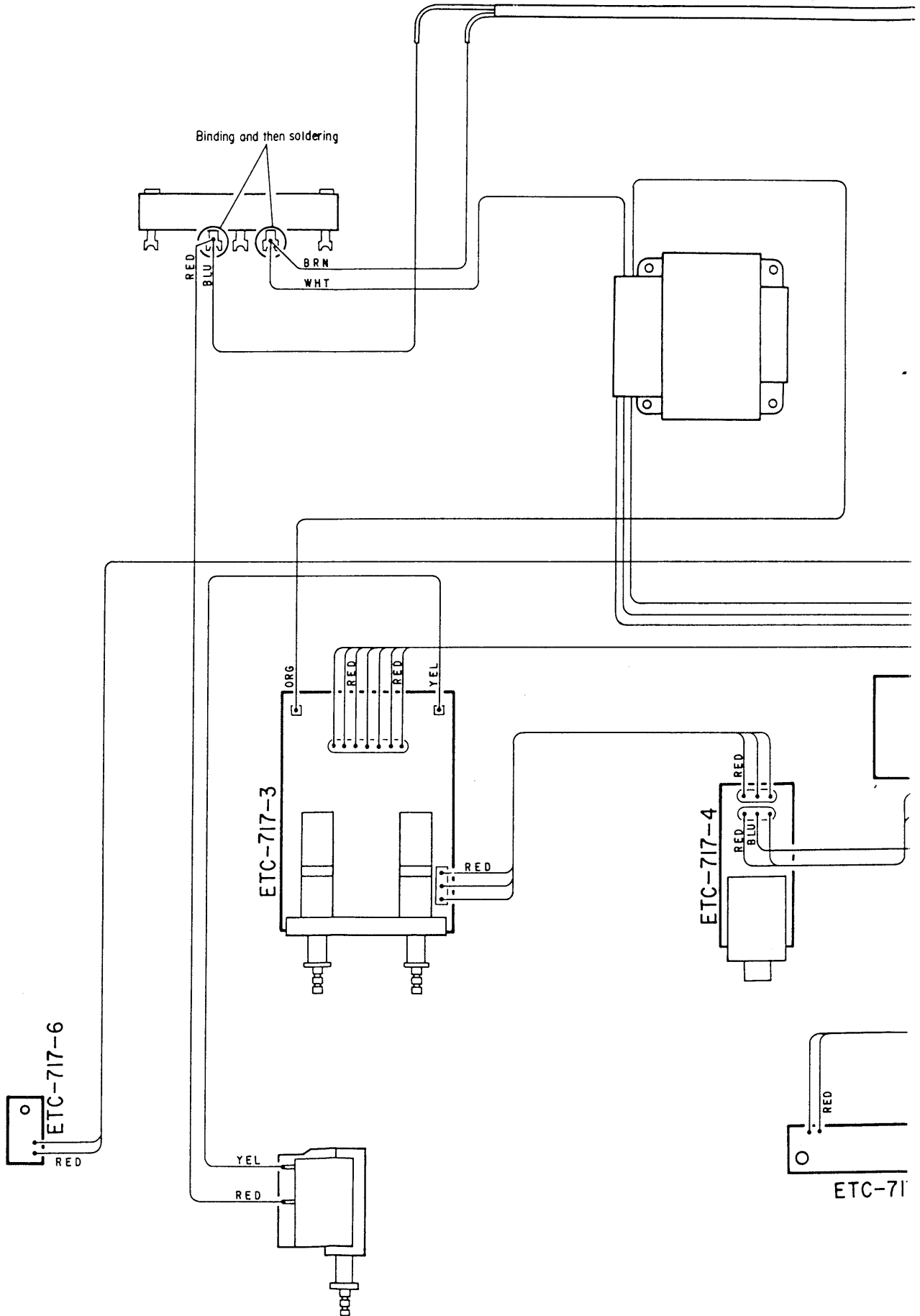

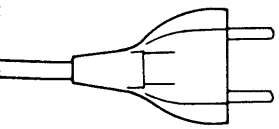

TO AC LINE

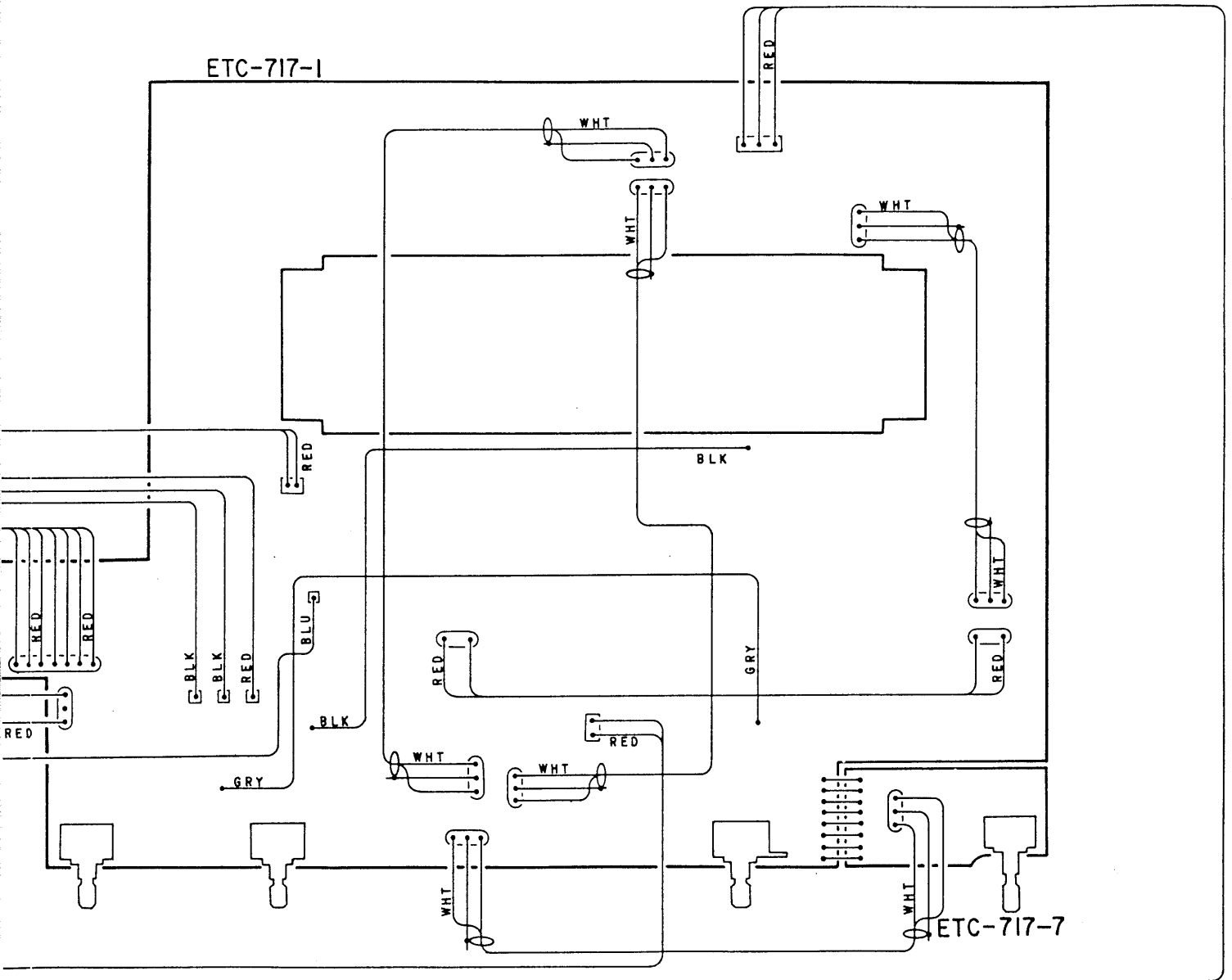

SYMBOL MARK

- CONNECTOR BASE
- WIRE HOLDER
- WIRE DIRECTINSERT
- WIRE WRAPPING

EXPLODED VIEW OF CHASSIS AND CABINET

 Means when necessary by the manufacturer

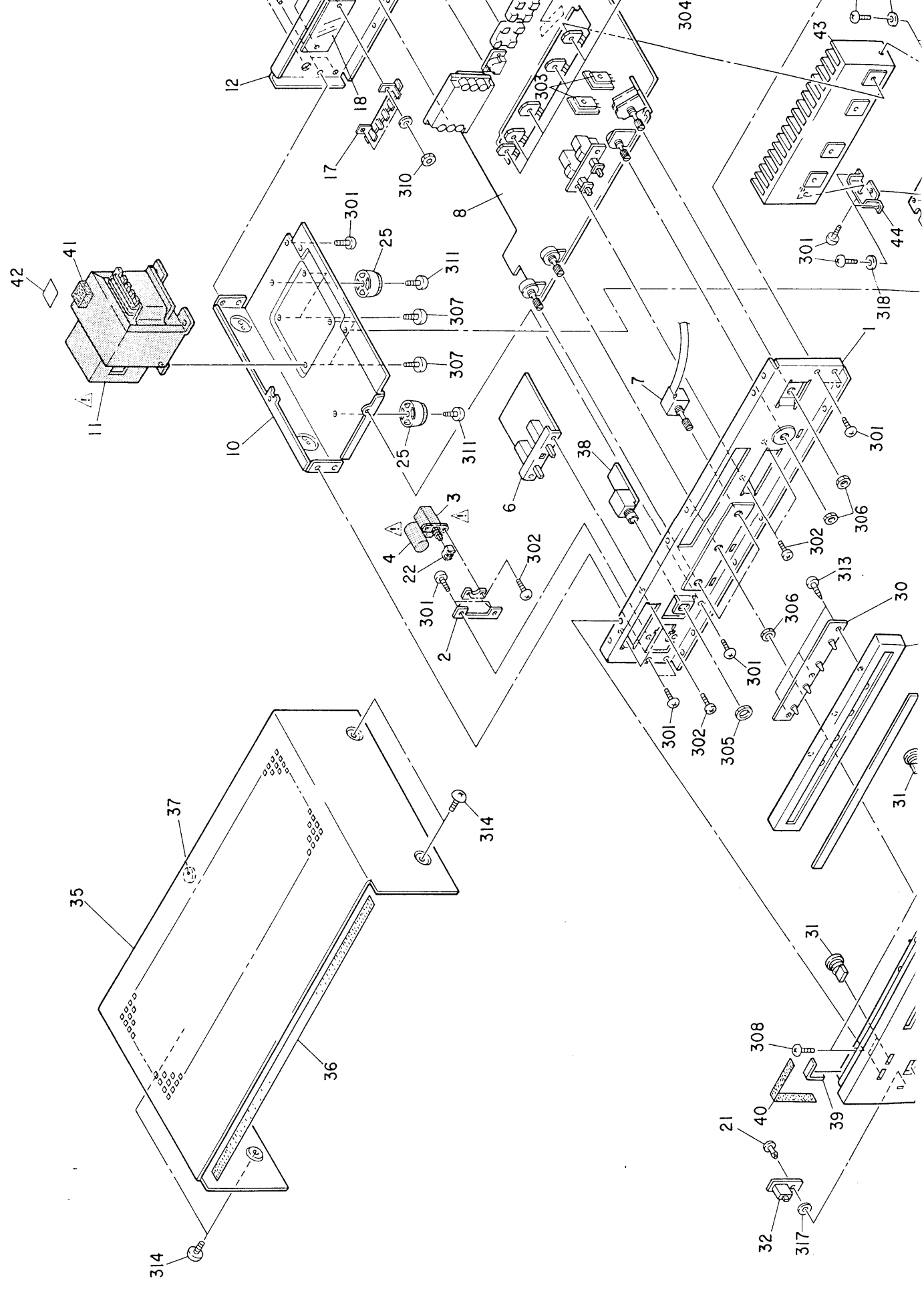

DENON

Important safety item, which must be replaced, only by a part specified or meeting the specification of.

ADDENDUM LIST

Ref. No.	Part Name & Descriptions	Part No.								
		E2	EK	E1	EA	Gold Version	E3	Black Version		
A 3	POWER SWITCH	2124154021	2124154021	2124154021	2124154021	2124154021	2124154021	2124154034	2124154034	
4	CAPACITOR (SPARK KILLER)	2568023035	2568023035	2368023035	2568023035	2568023035	2568023035	2568019007	2568019007	
6	SPEAKER SW UNIT	ETC0717L3	ETC0717L3	ETC0717K3	ETC0717N3	ETC0717M3	ETC0717M3	ETC0717M3	ETC0717M3	
8	POWER & CONTROL UNIT	ETC0717-1	ETC0717L1	ETC0717K1	ETC0717N1	ETC0717M1	ETC0717M1	ETC0717M1	ETC0717M1	
A 11	POWER TRANS	2335356003	2335356008	2335356009	2335356008	2335472000	2335472000	2335472000	2335472000	
12	BACK PANEL	1050604109	1050604109	1050604106	1050604109	1050616100	1050616100	1050616100	1050616100	
A 16	AC CORD	2062002031	2062020000	2006031026	2062012005	2062021009	2062021009	2062021009	2062021009	
17	7P W TERMINAL	2050089008	2050089008	—	2050089008	—	—	—	—	
18	INSULATING SHEET	4150088004	4150088004	—	4150088004	—	—	—	—	
A 19	CORD BUSH	4450020005	MD-2982H	4450028007	MD-2982H	—	—	4450020005	4450020005	
20	FTZ LABEL	5130716023	—	—	—	—	—	—	—	
21	PUSH RIVET	4770096007	4770096007	—	4770096007	—	—	—	—	
23	PUSH KNOB (A)	1130515011	1130515011	1130515027	1130515027	1130515011	1130515027	1130515027	1130515011	
26	FRONT PANEL ASS'Y	1441239316	1441239413	1441239400	1441239400	1441239413	1441239400	1441239400	1441239413	
28	WINDOW PANEL	1460694107	1460694107	1460694107	1460694107	1460694107	1460694107	1460694107	1460694107	
29	WINDOW	1430368214	1430368214	1430368201	1430368201	1430368214	1430368201	1430368214	1430368214	
30	LED SELECTOR UNIT	ETC0717-2	ETC0717L2	ETC0717K2	ETC0717N2	ETC0717M2	ETC0717M2	ETC0717M2	ETC0717M2	
31	PUSH KNOB (B) ASS'Y	1130513217	1130513217	1130513233	1130513233	1130513217	1130513233	1130513217	1130513217	
32	POWER LED UNIT	ETC0717-6	ETC0717L6	ETC0717K6	ETC0717N6	ETC0717M6	ETC0717M6	ETC0717M6	ETC0717M6	
33	KNOB (A) FOR MAIN	1120449016	1120449016	1120449003	1120449003	1120449016	1120449003	1120449016	1120449016	
34	KNOB (B) FOR BAL. SEL. TRE. BAS.	1120450018	1120450018	1120450005	1120450005	1120450018	1120450005	1120450018	1120450018	
35	TOP COVER	1020176010	1020176010	1020176007	1020176007	1020176010	1020176007	1020176010	1020176010	
38	H.P UNIT	ETC0717-4	ETC0717L4	ETC0717K4	ETC0717N4	ETC0717M4	ETC0717M4	ETC0717M4	ETC0717M4	
50	EARTH LABEL	—	5130140000	—	5130140000	—	—	—	—	
51	VOLTAGE LABEL	—	5139102007	—	5139102007	—	—	—	—	
52	BLIND SHEET	—	5130348006	—	5130348006	—	—	—	—	
53	CAUTION SHEET	—	5130364006	—	5130364006	—	—	—	—	
54	BLIND SHEET	—	4149001005	—	4149001005	—	—	—	—	
55	NOTICE SHEET	—	—	—	5130209006	—	—	—	—	
56	NOTICE SHEET	—	—	—	5130210008	—	—	—	—	
A 57	AC OUTLET UNIT	—	—	ETC0717K5	ETC0717K5	ETC0717M5	ETC0717M5	ETC0717M5	ETC0717M5	
A 58	VOLTAGE SEL SW	—	—	2120186006	2120186006	—	—	—	—	
59	PRESET LABEL	—	—	5150290008	5150290008	—	—	—	—	
60	FUSE LABEL	—	—	—	—	—	—	5130607048	5130607048	
61	DANGEROUS MARK	—	—	—	—	—	—	5138266009	5138266009	
62	SERIAL NO. PLATE	—	—	—	—	—	—	5130885006	5130885006	
63	RIVET	—	—	—	—	—	—	4770126016	4770126016	
64	—	—	—	—	—	—	—	—	—	
65	—	—	—	—	—	—	—	—	—	
66	—	—	—	—	—	—	—	—	—	
67	—	—	—	—	—	—	—	—	—	
68	—	—	—	—	—	—	—	—	—	
69	—	—	—	—	—	—	—	—	—	
70	—	—	—	—	—	—	—	—	—	
SCREWS AND NUTS										
309	PAN SCREW WITH S.W 3x8	4700042005	4700042005	4700042005	4700042005	4700042005	4700042005	4700042005	4700042005	
310	NUT M3	4756006008	4756006008	4756006008	4756006008	4756006008	4756006008	4756006008	4756006008	

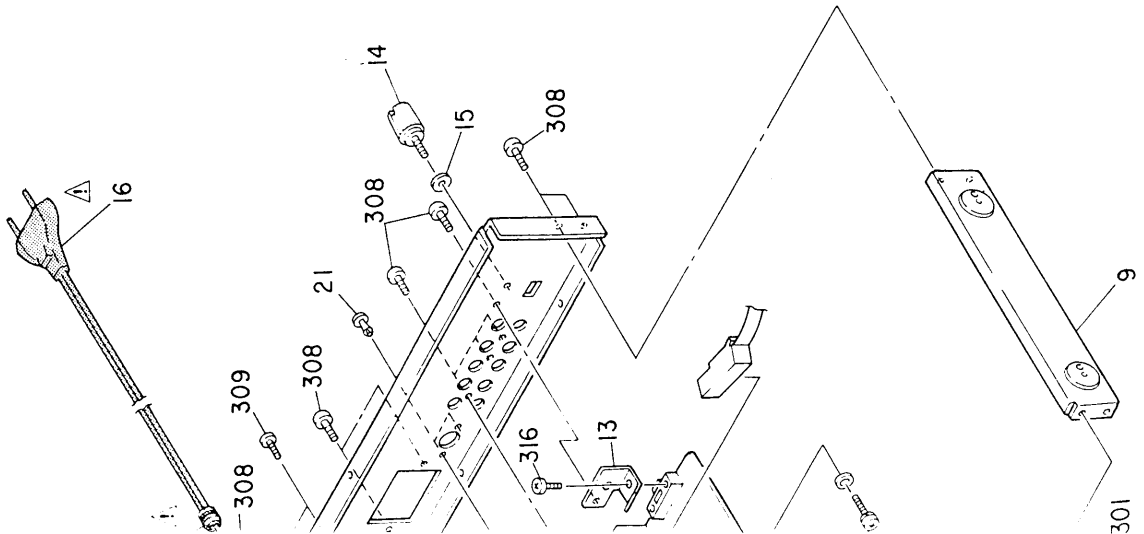

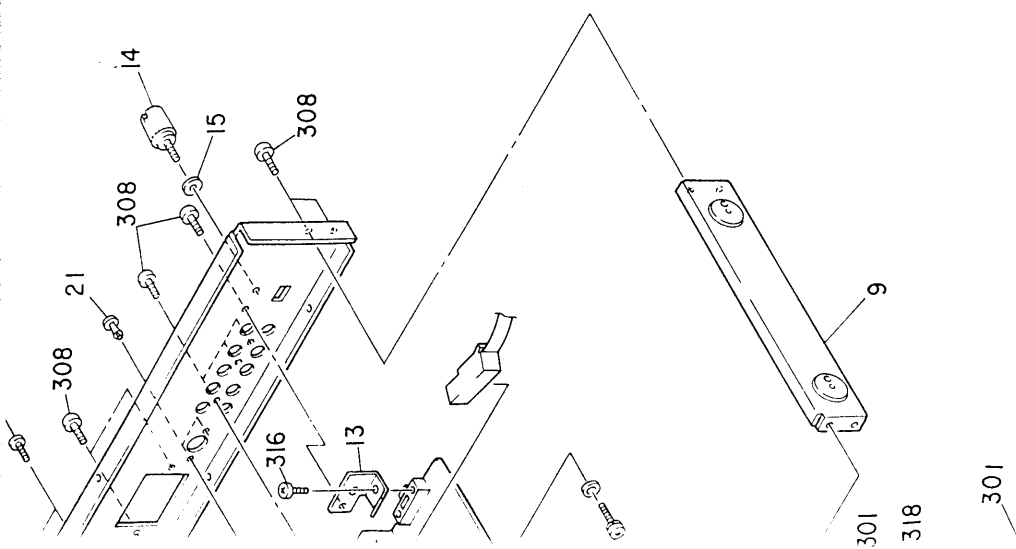

21	FUSE RIVET	4770096007	4770096007	1130515011	1130515027	1130515027	1130515027	1130515011	
23	PUSH KNOB (A)	1130515011	1130515011	1441239413	1441239400	1441239400	1441239400	1441239413	
26	FRONT PANEL ASS'Y	1460694107	1460694107	1460694107	1460694107	1460694107	1460694107	1460694107	
28	WINDOW PANEL	1430368214	1430368214	ETC0717-2	ETC0717K2	ETC0717M2	ETC0717M2	1430368214	
29	WINDOW	1130513217	1130513217	ETC0717L6	ETC0717K6	ETC0717M6	ETC0717M6	1130513217	
30	LED SELECTOR UNIT	1120449016	1120449016	1120450018	1120450005	1120450005	1120450005	1120449016	
31	PUSH KNOB (B) ASS'Y	1020176010	1020176010	ETC0717L4	ETC0717K4	ETC0717M4	ETC0717M4	1020176010	
32	POWER LED UNIT	5130140000	5130140000	5139102007	5130348006	5130348006	5130348006	5130140000	
33	KNOB (A) FOR MAIN	4149001005	4149001005	ETC0717-6	ETC0717K6	ETC0717M6	ETC0717M6	4149001005	
34	KNOB (B) FOR BAL. SEL. TRE. BAS.	5130209006	5130209006	5130210008	5130210008	5130210008	5130210008	5130209006	
35	TOP COVER	ETC0717K5	ETC0717K5	2120186006	2120186006	2120186006	2120186006	ETC0717M5	
38	H.P UNIT	5150290008	5150290008	ETC0717L4	ETC0717K4	ETC0717M4	ETC0717M4	5150290008	
50	EARTH LABEL	4700042005	4700042005	4756006008	4756006008	4756006008	4756006008	4700042005	
51	VOLTAGE LABEL	4734454038	4734454038	4753001051	4753001051	4753001051	4753001051	4734454038	
52	BLIND SHEET	4753100004	4753100004	4711303034	4711303034	4711303034	4711303034	4753100004	
53	CAUTION SHEET	5010915038	5010915038	5010915096	5010915096	5010915096	5010915096	5010915038	
54	BLIND SHEET	5020556005	5020556005	5130211007	5130211007	5130211007	5130211007	5020556005	
55	NOTICE SHEET	5111041005	5111041005	5158053001	5158053001	5158053001	5158053001	5111041005	
56	NOTICE SHEET	5158053001	5158053001	5158053001	5158053001	5158053001	5158053001	5158053001	
A 57	AC OUTLET UNIT								
A 58	VOLTAGE SEL SW								
59	PRESET LABEL								
60	FUSE LABEL								
61	DANGEROUS MARK								
62	SERIAL NO. PLATE								
63	RIVET								
64									
65									
66									
67									
68									
69									
70									
SCREWS AND NUTS									
309	PAN SCREW WITH S.W 3x8	4700042005	4700042005	4700042005	4700042005	4700042005	4700042005	4700042005	
310	NUT M3	4756006008	4756006008	4756006008	4756006008	4756006008	4756006008	4756006008	
314	TAPPING SCREW 4x8	4734454038	4734454038	4734454038	4734454038	4734454038	4734454038	4734454038	
350	TOOTH WASHER φ3	4753001051	4753001051	4753001051	4753001051	4753001051	4753001051	4753001051	
351	TOOTH WASHER φ4	4753100004	4753100004	4753100004	4753100004	4753100004	4753100004	4753100004	
352	PAN SCREW 3x6 (BLACK)								
353									
354									
c.	CARTON CASE	5010915054	5010915054	5010915096	5010915038	5010915038	5010915038	5010915054	
e.	IMPORTANT LABEL			5130372001					
f.	PAD								
g.	CAUTION PAPER								
h.	SAFETY INSTRUCTION								
i.	SAFETY INSTRUCTION								
j.	WARRANTY IN ENVELOPE								
k.	WARRANTY IN ENVELOPE								

NIPPON COLUMBIA CO., LTD.

No. 14-14, 4-CHOME AKASAKA,
 MINATO-KU, TOKYO 107 JAPAN
 TEL: 03-584-8111
 TLX: JAPANOLA J22591
 CABLE: NIPPONCOLUMBIA TOKYO

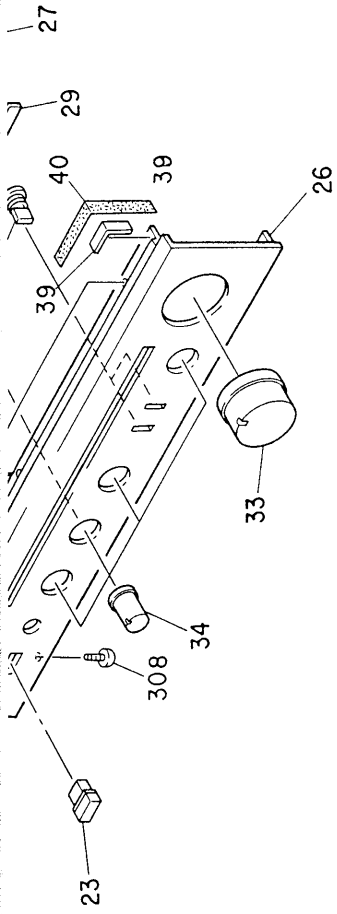
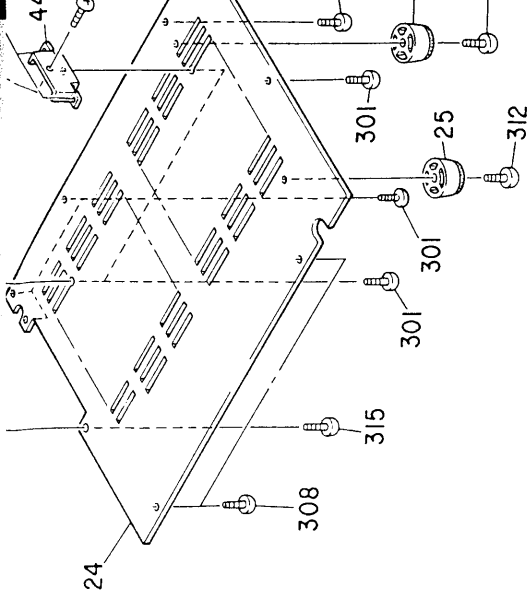

EXPLODED VIEW PARTS LIST

Note: 1. See addendum list below for the parts with asterisk (*) on the Ref. No. and the other parts not included in the list.
 2. * Marked not included EXPLODED VIEW.
 3. This list is prepared based on E2 Red gold version.

Ref. No.	Part No.	Part Name & Descriptions
1	4110420301	FRONT CHASSIS
2	4121642107	SWITCH BRACKET
Δ *3	2124154021	POWER SWITCH
Δ *4	2568023035	0.047μF/250V METALIZED CAP.
*5	4450033005	WIRE CLAMP BAND 10
*6	ETC0717-3	SPEAKER SW UNIT
7	2120252008	ROTARY REMOTE
*8	ETC0717-1	POWER & CONTROL UNIT
9	4121082013	SIDE CHASSIS
10	4121083119	TRANS CHASSIS
Δ *11	2335356003	POWER TRANS
*12	1050604109	BACK PANEL
13	4121099103	SLIDE SW BRACKET
14	2050071016	TERMINAL ASS'Y
15	4770018001	WASHER (P-87)
Δ *16	2062002031	AC CORD
Δ *17	2050089008	7P.W TERMINAL
*18	4150088004	INSULATING SHEET
Δ *19	4450020005	CORD BUSH
*20	5130716023	FTZ LABEL
*21	4770096007	PUSH RIVET
*22	1140056007	FLEXIBLE RING
*23	1130515134	PUSH KNOB (A)
24	1050485108	BOTTOM COVER
25	1048001002	FOOT

Ref. No.	Part No.	Part Name & Descriptions
*26	1441239400	FRONT PANEL ASS'Y SILVER
27	1460694107	WINDOW PANEL
*28	-	-
*29	1430368201	WINDOW
*30	ETC0717-2	LED SELECTOR UNIT
*31	1130513233	PUSH KNOB (B) ASS'Y
*32	ETC0717-6	POWER LED UNIT
*33	1120449003	KNOB (A) FOR MAIN
*34	1120450005	KNOB (B) FOR BAL. SEL. TRE. BAS.
*35	1020176007	TOP COVER
36	1220069008	SPACER
37	1040034006	STOPPER
*38	ETC0717-4	H.P. UNIT
39	4410454006	CORNER PLATE
40	1220069040	SPACER
41	4610136014	RUBBER SHEET
42	4150208017	INSULATING SHEET
43	4170175007	POWER RADIATOR
44	4121079000	RADIATOR BRACKET
45	-	-
46	-	-
47	-	-
		SCREWS AND NUTS
301	4730354019	TAPPING SCREW (2) 3x8
		Q'ty
		20

Ref. No.	Part N°	Part Name & Descriptions
302	47113C J1	PAN SCREW 3x6
303	473035301 J	TAPPING SCREW (2) 3x6
304	4700012022	PAN SCREW WITH W. S.W 3x12
305	-	NUT M12
306	-	NUT M7
307	4734454012	TAPPING SCREW (TRUS) 4x8
308	4730354035	TAPPING SCREW (2) 3x8 (BLACK)
309	4700042005	PAN SCREW WITH S.W 3x8
310	4756006008	NUT M3
311	4730455031	TAPPING SCREW (2) 4x10
312	4730454016	TAPPING SCREW (2) 4x8
313	4730304014	TAPPING SCREW (1) 3x8
*314	4734801005	TAPPING SCREW (TRUS) 4x8 (NI)
315	4730805018	TAPPING SCREW 3x5
316	4711201013	PAN SCREW 2.6x4
317	4770231008	WASHER 4W(S)
318	4751106071	WASHER
PACKING & ACCESSORIES (not included EXPLODED VIEW)		
*a.	5050075006	CABINET COVER
b.	5030330004	CUSHION
*c.	5010915038	CARTON CASE
d.	5111225009	INST. MANUAL
e.	-	-
f.	-	-

351 TOOTH WASHER φ4	4753001051	4753001051	4753001051	4753001051	4753001051	4753001051
352 PAN SCREW 3x6 (BLACK)	4753100004	4753100004	4753100004	4753100004	4753100004	4753100004
353	—	—	—	—	—	—
354	4711303034	4711303034	4711303034	4711303034	4711303034	4711303034
c. CARTON CASE	5010915054	5010915096	5010915038	5010780282	5010979045	5010979087
e. IMPORTANT LABEL	—	5130372001	—	—	—	—
f. PAD	—	—	—	5020556005	—	—
g. CAUTION PAPER	—	—	—	5130211007	—	—
h. SAFETY INSTRUCTION	—	—	—	—	5111041005	5111041005
i. WARRANTY IN ENVELOPE	—	—	—	—	5158053001	5158053001
j.	—	—	—	—	—	—
k.	—	—	—	—	—	—

NIPPON COLUMBIA CO., LTD.

No. 14-14, 4-CHOME AKASAKA,

MINATO-KU, TOKYO 107 JAPAN

TEL: 03-584-8111

TLX: JAPANOLA J22591

CABLE: NIPPONCOLUMBIA TOKYO

Printed in Japan

6	2	5	1	5	4	15	2	2	2	2	3	4	2	1	1	4
---	---	---	---	---	---	----	---	---	---	---	---	---	---	---	---	---

For Service Manuals
MAURITRON SERVICES
 8 Cherry Tree Road, Chinnor
 Oxfordshire, OX9 4QY.
 Tel (01844) 351694
 Fax (01844) 352554
 email:- sales@mauritron.co.uk

WIRING DIAGRAM

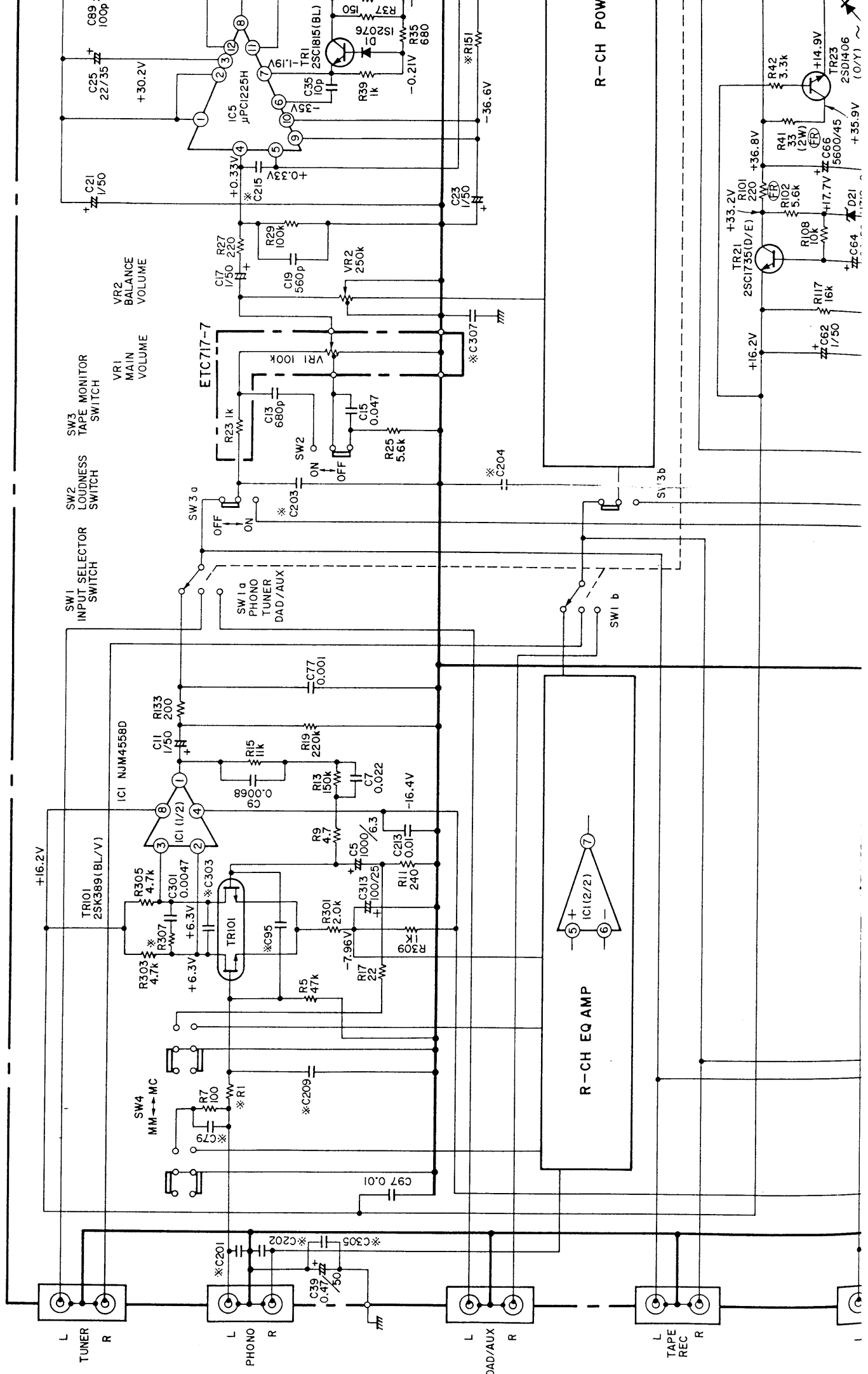

R-CH EQ AMP

R-CH POW

⚠ Means important safety item, which must be replaced, when necessary, by a part specified or meeting the specification by the manufacturer.

SEMICONDUCTORS

- IC's

NJM4558D(JR)

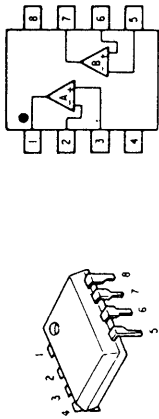

μPC1225H(NEC)

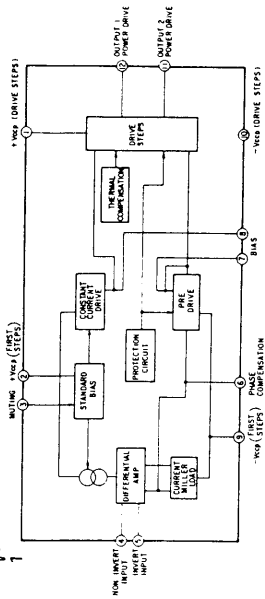
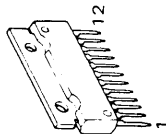

TRANSISTORS

2SA564A(R)
2SC1815(BL)

2SD1406(O)/(Y)

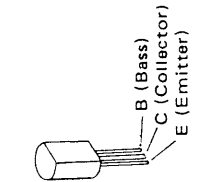

2SA1102(O/Y)
2SC2577(O/Y)

2SA850(D/E)
2SC1735(D/E)

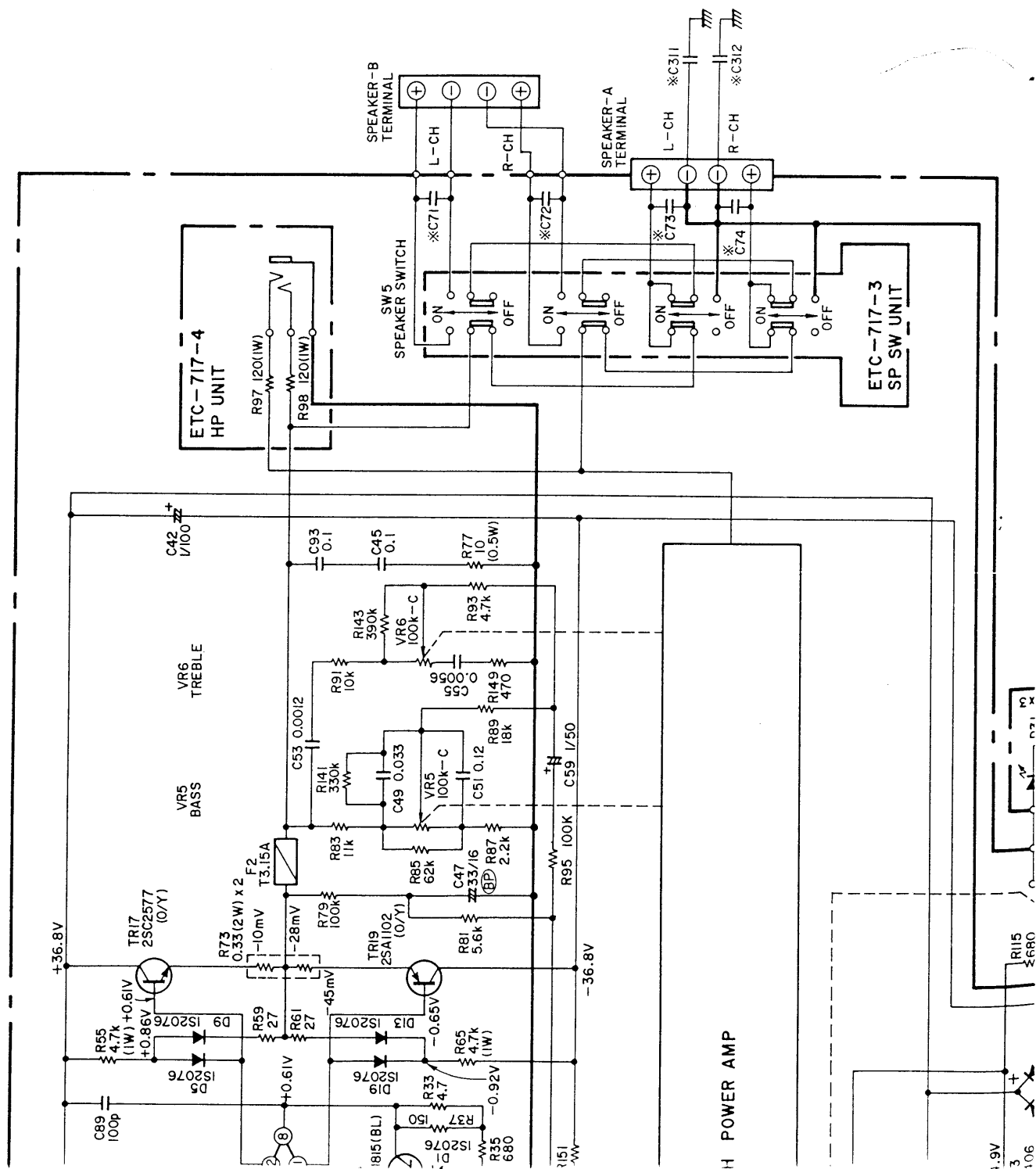

H POWER AMP



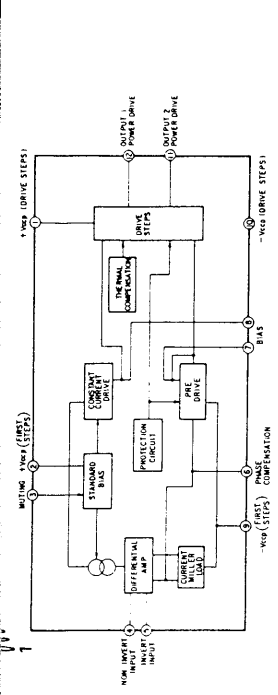
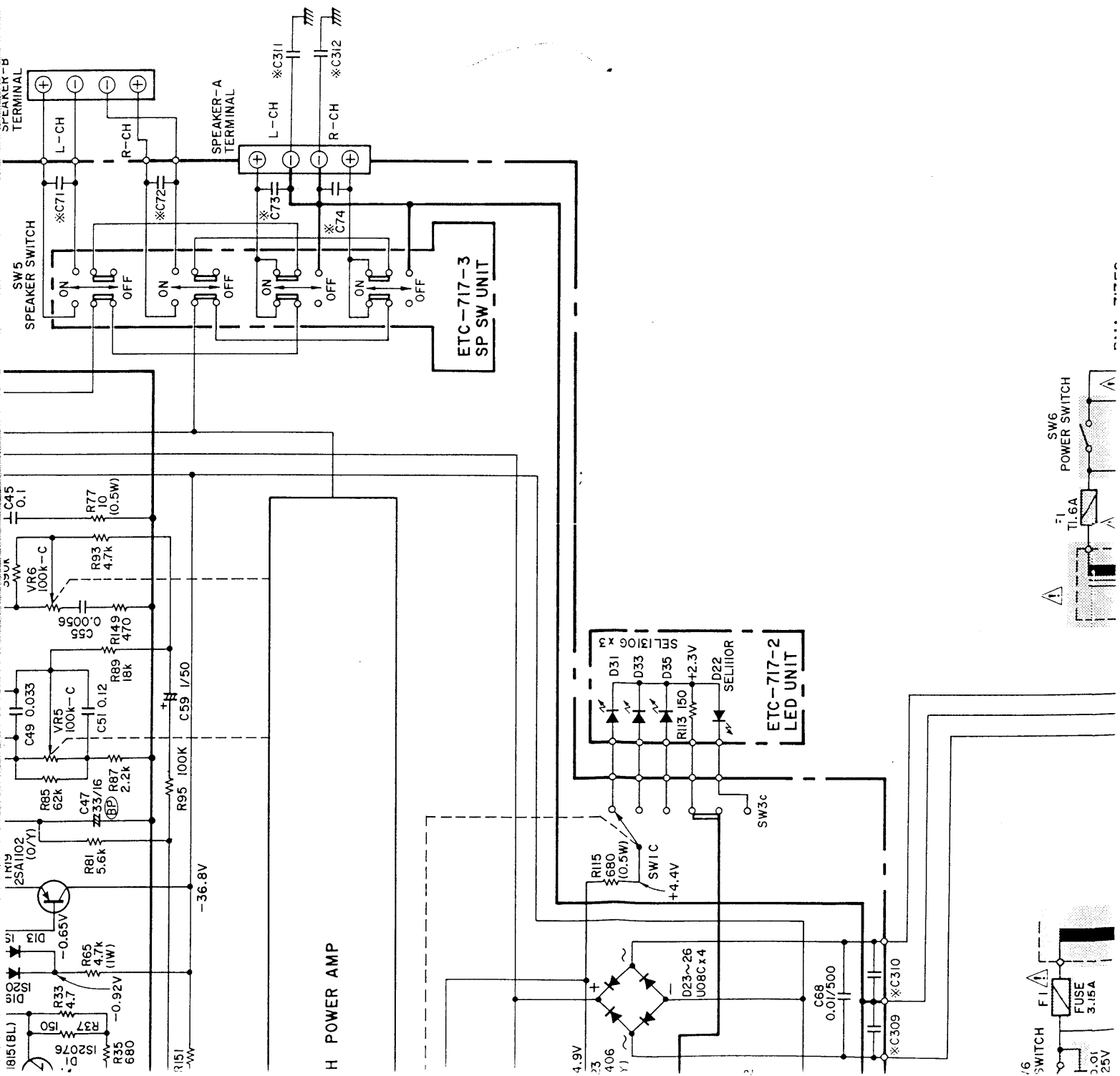

● TRANSISTORS

- 2SA564A(R)
- 2SC1815(BL)

- 2SD1406(O)/(Y)

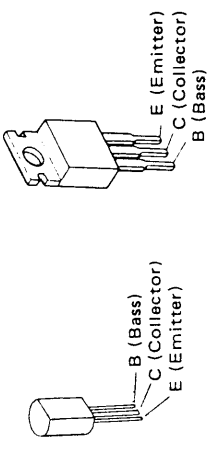

- 2SA1102(O/Y)
- 2SC2577(O/Y)

- 2SA850(D/E)
- 2SC1735(D/E)

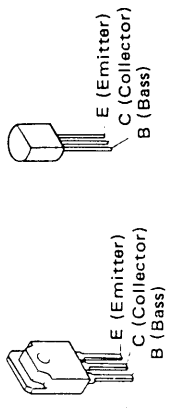

● DIODE

- 1S2076

- HZ18-2

- U08C

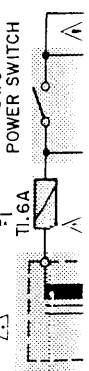

SEL110R(Red)
SEL1310G(Green)

PR5552K-1(Red)

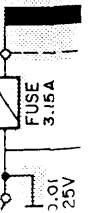

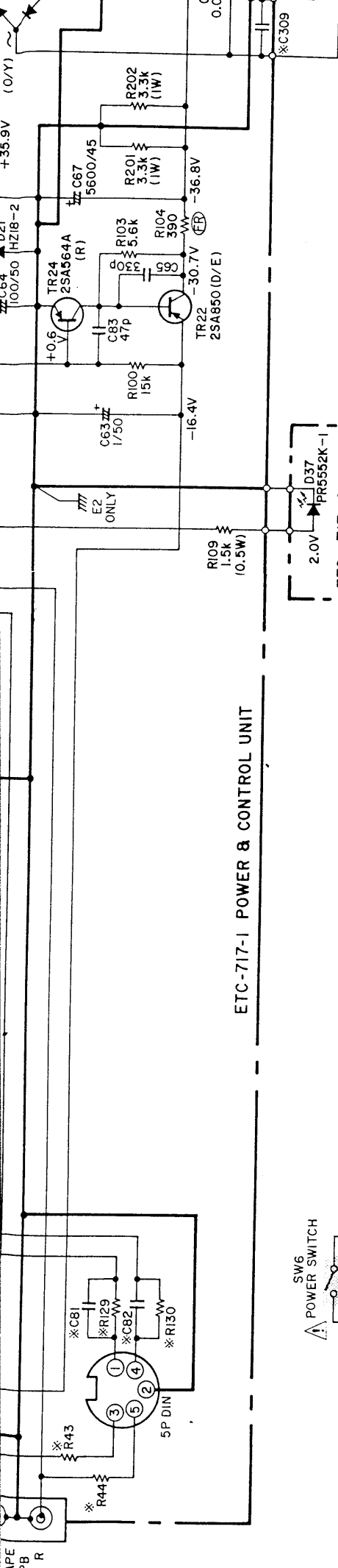

ETC-717-1 POWER & CONTROL UNIT

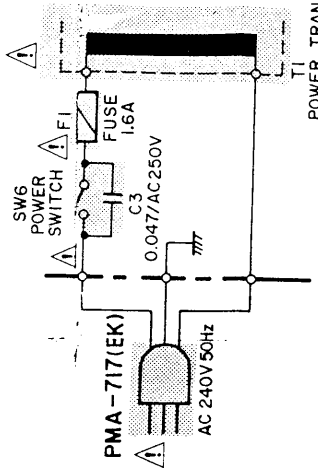
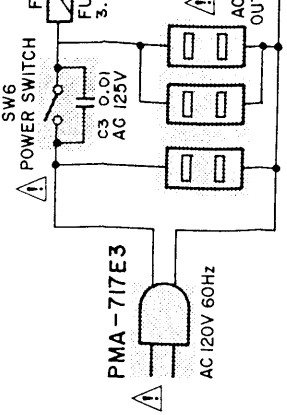
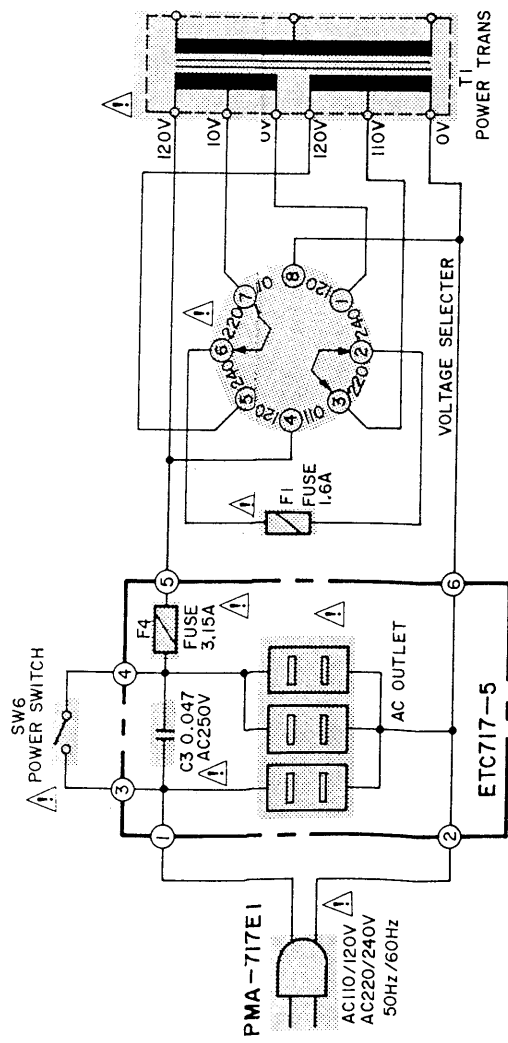
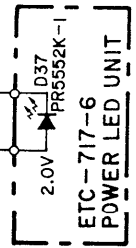

Model	Symbol	R307,308	C203, 204	C81,82	R129,130	R43,44	C95,96	C201,202	C71~74 C79,80	R151,152	C309,310	C215, 216	C311,312	C303,304	C305
E2	5p DIN JACK	560	220p	18p	470k	100	560p	27p	0.01	4.7(FR)	0.01/500	100p	3300p	10p	0.01
E1, E3	DELETE	470	DELETE	DELETE	DELETE	DELETE	DELETE	DELETE	DELETE	JUMPER	DELETE	DELETE	DELETE	DELETE	DELETE
EA, EC, EK	5p DIN JACK	470	DELETE	18p	470k	100	DELETE	DELETE	DELETE	JUMPER	DELETE	DELETE	DELETE	DELETE	DELETE

For Service Manuals
MAURITRON SERVICES
 8 Cherry Tree Road, Chinnor
 Oxfordshire, OX9 4QY.
 Tel (01844) 351694
 Fax (01844) 352554
 email:- sales@mauritron.co.uk

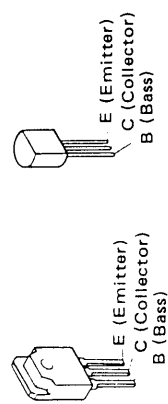

• DIODE

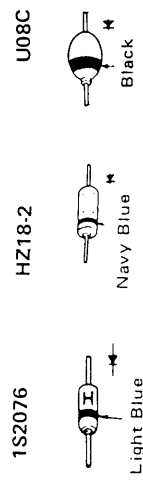

SEL110R (Red)
SEL1310G (Green)



FET
2SK389(BL)/(V)

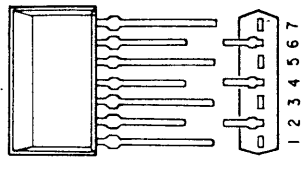

1. Drain 1
2. Gate 1
3. Source 1
4. Substrate
5. Source 2
6. Gate 2
7. Drain 2

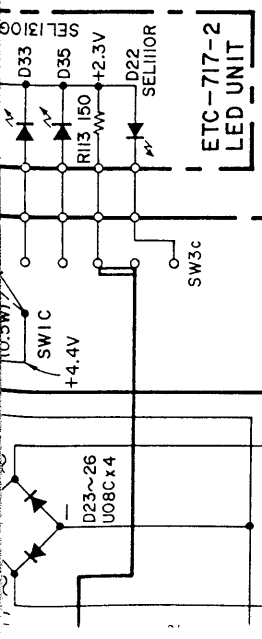

ETC-717-2
LED UNIT

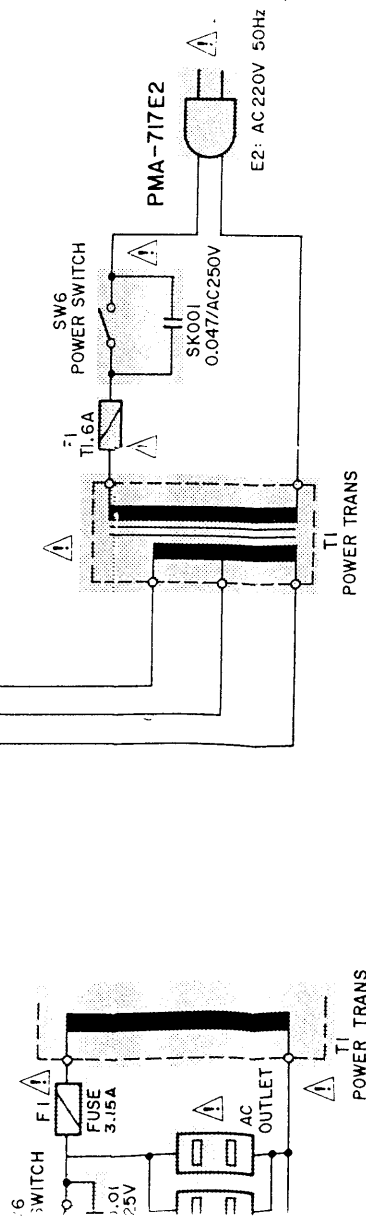

NOTES:
ALL RESISTANCE VALUES IN OHM, K = 1,000 OHM,
M = 1,000,000 OHM.
ALL CAPACITANCE VALUES IN MICROFARAD, P = MICRO-
MICRO FARAD.
EVERY VOLTAGES AND CURRENTS IS MEASURED AT
NO SIGNAL INPUT CONDITION.
CIRCUIT AND PARTS ARE SUBJECT TO CHANGE WITHOUT
PRIOR NOTICE.

4	C305	R1,2	C209,210	C307
	0.01	330	750P	0.01
	DELETE	10	220P	JUMPER
	DELETE	10	220P	JUMPER

For Service Manuals
MAURITRON SERVICES
8 Cherry Tree Road, Chinnor
Oxfordshire, OX9 4QY.
Tel (01844) 351694
Fax (01844) 352554
email:- sales@mauritron.co.uk